

idOil-LIQ

High liquid level sensor



Table of contents

1 General information about the manual	3
1.1 Markings and symbols	3
1.2 Conformity of the product	3
1.3 Limitation of liability	3
2 Safety and the environment	4
2.1 General safety instructions	4
2.2 Intended use	4
2.3 Installation and commissioning	4
2.4 Transport and storage	4
2.5 Repair	5
2.6 Decommissioning and disposal	5
3 Product description	6
3.1 Device operation	6
3.2 Dimensions idOil-LIQ high liquid level sensor	6
4 Installation	7
4.1 General installation instructions for sensors	7
4.2 Installing the idOil-LIQ high liquid level sensor	7
5 Connections	8
5.1 idOil sensor connected to idOil control unit	8
5.2 idOil-LIQ sensor connected to SET control unit	9
6 Functional test	12
6.1 idOil-LIQ sensor functional test with idOil control unit	12
6.2 idOil-LIQ sensor functional test with SET control unit	12
7 Maintenance	13
8 Troubleshooting	14
8.1 idOil sensor troubleshooting with idOil control unit	14
8.2 idOil-LIQ sensor troubleshooting with SET control unit	15
9 Technical specifications idOil-LIQ high liquid level sensor	16
10 Appendix EU Declaration of Conformity	17

1 General information about the manual

This manual is an integral part of the product.

- Please read the manual before using the product.
- Keep the manual available for the entire duration of the product's life span.
- Provide the manual to the next owner or user of the product.
- Please report any errors or discrepancies related to this manual before commissioning the device.

1.1 Markings and symbols

Safety-related markings and symbols



This marking warns of a possible hazard. Failing to observe the safety instructions in question may result in injury or death.



This marking warns of a fault or hazardous situation. Failing to observe the safety instructions in question may result in injury or device breakage.



This marking warns of a possible fault. Failing to observe the safety instructions in question may result in device or system breakage or erroneous operation.



This marking emphasises an issue that requires special attention during installation and when using the device in an explosive atmosphere.

Informative markings and symbols



This marking highlights essential information.



This marking refers to a user measure.

1.2 Conformity of the product

The EU declaration of conformity and the product's technical specifications are integral parts of this document.

All of our products have been designed and manufactured with due consideration to the essential European standards, statutes and regulations.

Labkotec Oy has a certified ISO 9001 quality management system and ISO 14001 environmental management system.

1.3 Limitation of liability

Due to continuous product development, we reserve the right to change these operating instructions.

The manufacturer cannot be held liable for direct or indirect damage caused by neglecting the instructions provided in this manual or directives, standards, laws and regulations regarding the installation location.

The copyrights to this manual are owned by Labkotec Oy.

2 Safety and the environment

2.1 General safety instructions

The plant owner is responsible for the planning, installation, commissioning, operation, maintenance and disassembly at the location.

Installation and commissioning of the device may be performed by a trained professional only.

Protection of operating personnel and the system is not ensured if the product is not used in accordance with its intended purpose.

Laws and regulations applicable to the usage or the intended purpose must be observed. The device has been approved for the intended purpose of use only. Neglecting these instructions will void any warranty and absolve the manufacturer from any liability.

2.2 Intended use

The idOil-LIQ sensor is intended to be used as liquid high level alarm in oil and sand separators.

The sensor can be placed in a zone 0 explosive atmosphere, but the control unit connected with have to be placed in a safe area.

A more specific description of the product's operation, installation and use is provided later in this manual.

The device must be used in accordance with the instructions provided in this document. Other use is counter to the product's purpose of use. Labkotec cannot be held liable for any damage caused by using the device in violation of its purpose of use.

2.3 Installation and commissioning



The sensor can be installed in potentially explosive atmospheres of zones 0, 1 and 2. In potentially explosive area installations, the national regulations and appropriate standards IEC/EN 60079-25 Intrinsically safe electrical systems "i" and/or IEC/EN 60079-14 Explosive atmospheres - Electrical installations design, selection and erection must all be followed..



If it is possible that static electricity can cause hazards in the measurement environment, equipotential bonding must be attended according to the regulations concerning potentially explosive atmospheres. Equipotential bonding is done by connecting all conductive parts to the same potential e.g. in a junction box. Equipotential bonding system must be grounded.



The instructions concerning the inspection and maintenance of Ex equipment contained in the standards IEC/EN 60079-17 and IEC/EN 60079-19 should be observed when executing service, inspection or repair procedures in potentially explosive atmospheres.

2.4 Transport and storage

Check the packaging and its content for any possible damage.

Ensure that you have received all the ordered products and that they are as intended.

Keep the original package. Always store and transport the device in the original packaging.

Store the device in a clean and dry space. Observe the permitted storage temperatures. If the storage temperatures have not been presented separately, the products must be stored in conditions that are within the operating temperature range.

2.5 Repair

The device may not be repaired or modified without the manufacturer's permission. If the device exhibits a fault, it must be delivered to the manufacturer and replaced with a new device or one repaired by the manufacturer.

2.6 Decommissioning and disposal

The device must be decommissioned and disposed of in compliance with local laws and regulations.

3 Product description

3.1 Device operation

The idOil-LIQ sensor can be connected to Labkotec Oy analog (SET-1000 and SET-2000 - product family) or digital (idOil-product family) control units. The sensor issues an alarm signal when the liquid level in the separator reaches the sensor in overflow situation.

Applications are sand/sludge separators and oil separators.

The sensor has device classification 1 and it can be installed in zone 0, 1 and 2 hazardous area.

3.2 Dimensions idOil-LIQ high liquid level sensor

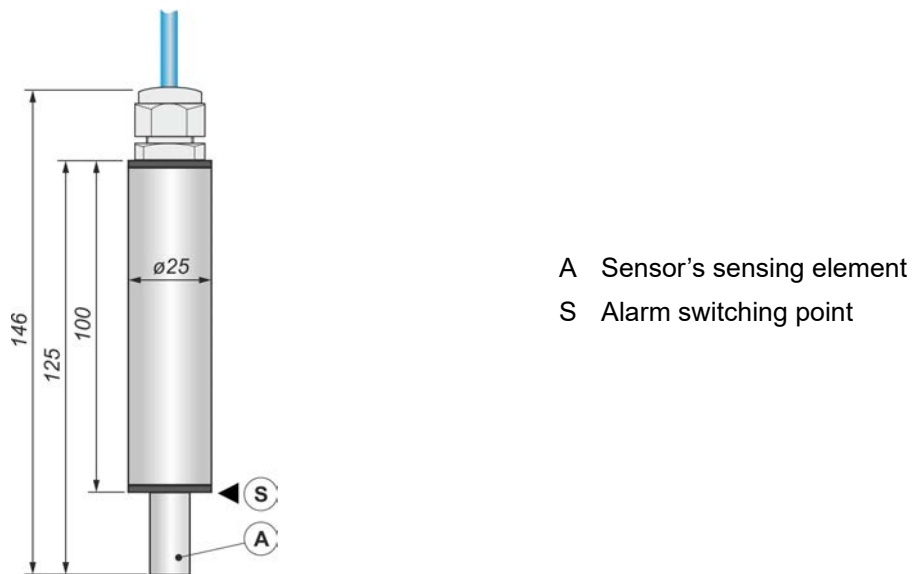

Figure 1. High liquid level sensor idOil-LIQ – structure and dimensions (mm)

4 Installation

4.1 General installation instructions for sensors



idOil sensors can be installed in zone 0 explosive atmospheres. Do not remove the sensor markings from the cables or sensor frames.



Read Section *General safety instructions* before installation.



Check the correct installation depth of the sensor in the instructions of the separator in question.

For example, sensors can be installed suspended from their cable (see next figure). Leave a sufficient length of the sensor or extension cable coiled inside the service well, so that you can easily lift the sensor out for inspection and cleaning.

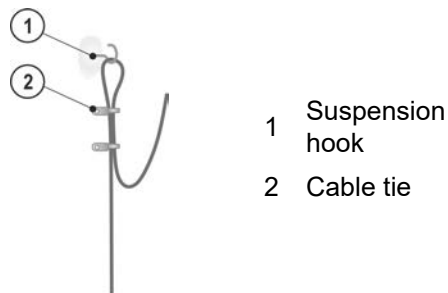

Figure 2. Sensor suspension example



Figure 3. Sensor mounting supplies LMS-SAS5

4.2 Installing the idOil-LIQ high liquid level sensor

The sensor is normally in air, and it issues an alarm when the sensing element is submerged in liquid. The sensor is installed at a suitable height above the standard liquid level (L) so that the overflow alarm is activated once the liquid level reaches the sensing element.

Overflow is possible in the following cases, for example:

- if the filter is dirty
- if the automatic closure device is blocked
- or if some other situation causes blockage in the discharge pipe

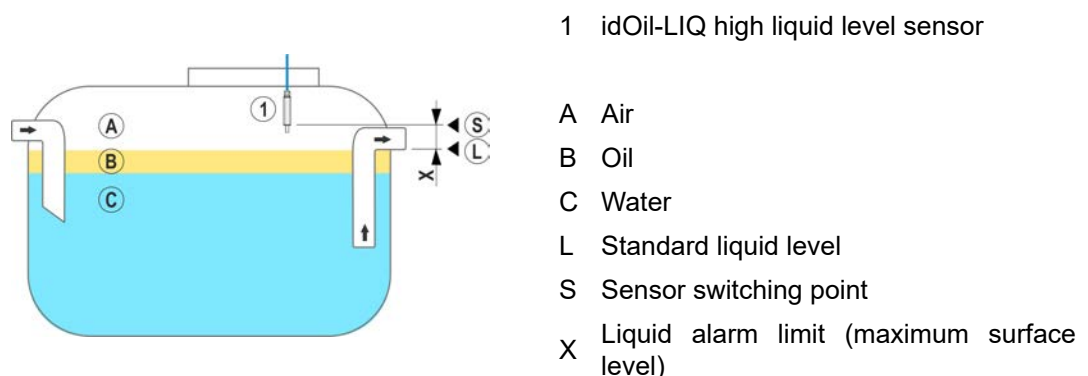
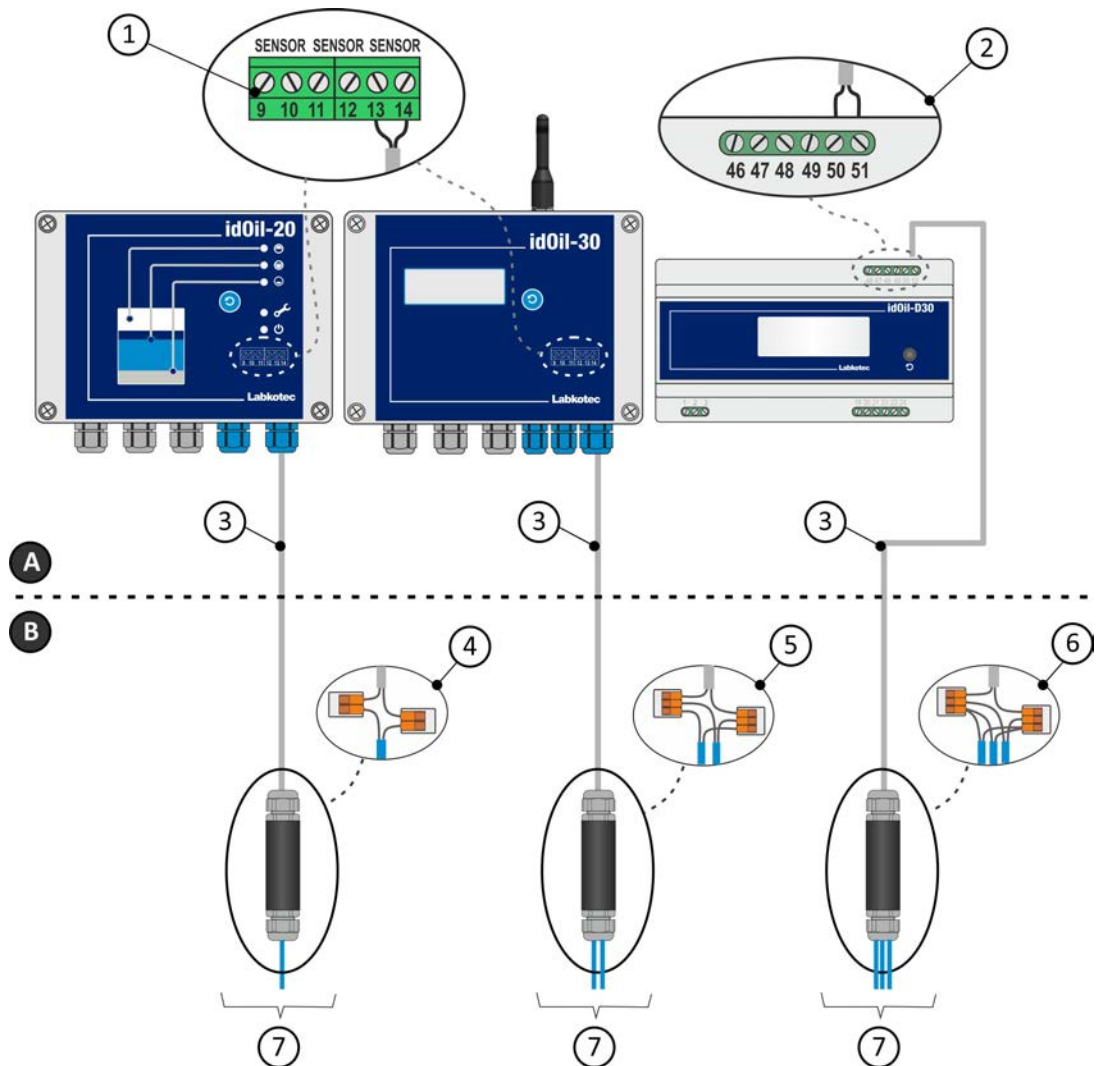

Figure 4. Installing the idOil-LIQ high liquid limit sensor

5 Connections

5.1 idOil sensor connected to idOil control unit



Kuva 5 . Connecting idOil sensor(s) to idOil control units

- A** Safe area
- B** Hazardous area

i The sensor connection is polarity free digital bus connection so the sensor can be connected to any of the sensor connectors (sensor 1, sensor 2 or sensor 3). Also, it doesn't make any difference to which terminals of sensor connectors the sensor wires are connected.

- 1 Sensor connectors idOil-20, idOil-30/idOil-30 3G, idOil-30 Battery/idOil-30 Battery 3G**
 - 9 = sensor 1, connection 1
 - 10 = sensor 1, connection 2
 - 11 = sensor 2, connection 1
 - 12 = sensor 2, connection 2
 - 13 = sensor 3, connection 1
 - 14 = sensor 3, connection 2

- 2 Sensor connectors idOil-D30**
 - 46 = sensor 1, connection 1
 - 47 = sensor 1, connection 2
 - 48 = sensor 2, connection 1
 - 49 = sensor 2, connection 2
 - 50 = sensor 3, connection 1
 - 51 = sensor 3, connection 2

- 3** Extension cable, e.g. protected, twisted-pair 2 x 0.5 mm², maximum resistance 68 Ohm. Extra wires and shield must be cut and isolated carefully.
- 4** Example cable connector LCJ1-1 for a single sensor
- 5** Example cable connector LCJ121 for two sensors
- 6** Example cable connector LCJ1-3 for three sensors
- 7** idOil-LIQ sensor

Product code 8540706 including:

- idOil-LIQ sensor
- LMS-SAS5 mounting kit for sensor

5.2 idOil-LIQ sensor connected to SET control unit

The sensor of the idOil product family can be connected to the control unit of Labkotec Oy's SET product family in place of the SET sensor. The difference is that the cable in the idOil series sensors has no shielding and the polarity of the conductors does not matter because the sensor connection is polarity-free.

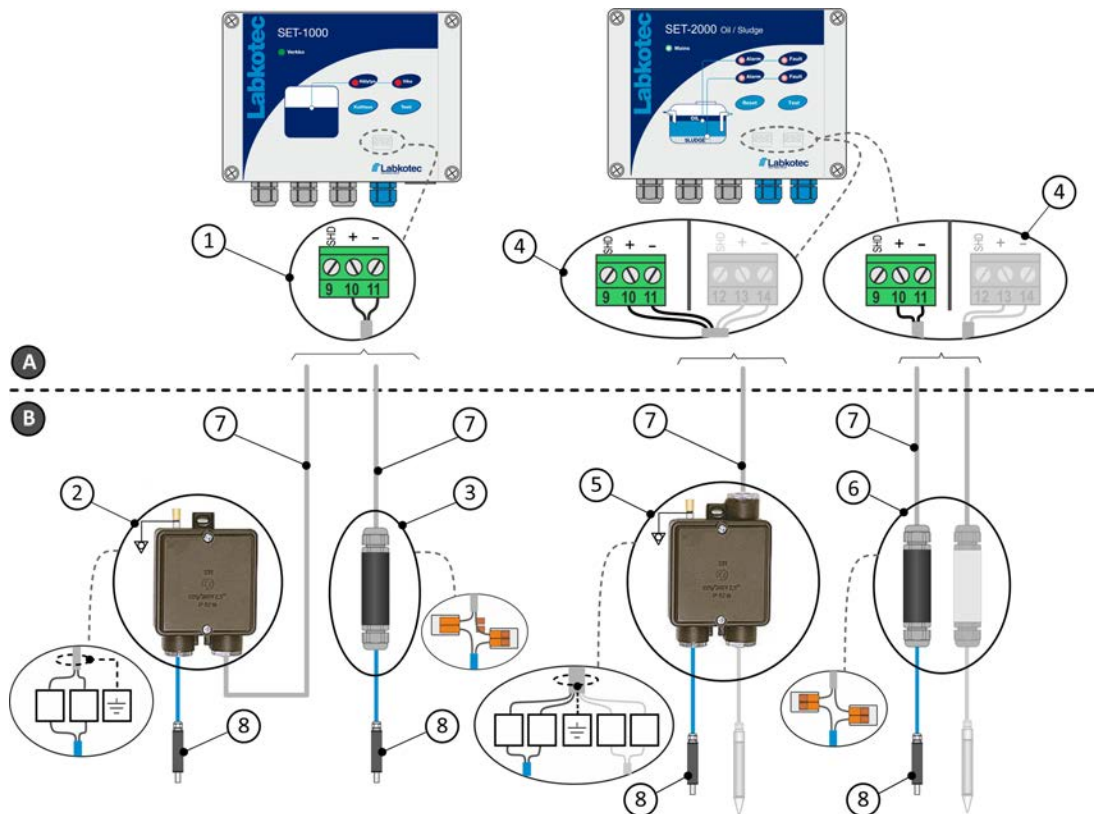

Kuva 6. Connecting idOil-SLU to SET control units

- A** Safe area
- B** Hazardous area

 The sensor connection is polarity free so the sensor wires can be connected to any of the sensor terminals (+ or -).

1 Sensor connector SET-1000

9 = SHD
10 = +
11 = -

Shield is not connected to the control unit. Extra wires and shield must be cut and isolated carefully.

2 Junction box LJB2-78-83 for a single sensor (rubber seal of the sensor cable gland must be changed when idOil sensor is used). Extra wires and possible shield are connected to the earthing connector of the junction box.

3 Cable connector LCJ1-1 for a single sensor (replaces LCJ1-SK4 cable connector). Extra wires and shield must be cut and isolated carefully.

4 Sensor connector SET-2000 Hi Level/Oil

9 = SHD
10 = +
11 = -

Shield is not connected to the control unit. Extra wires and shield must be cut and isolated carefully.

5 Junction box LJB3-78-83 for two sensors (rubber seal of the sensor cable gland must be changed when idOil sensor is used). Extra wires and possible shield are connected to the earthing connector of the junction box.

6 Cable connector LCJ1-1 for a single sensor. Extra wires and shield must be cut and isolated carefully.

7 Extension cable, e.g. protected, twisted-pair 2 x 0.5 mm², maximum resistance 68 Ohm.

8 idOil-LIQ spare part sensor for SET-1000 and SET-2000 control units

Product code 8540706SP including:

- idOil-LIQ sensor
- LCJ1-1 cable connector
- Rubber seal for LJB2-78-83 and LJB3-78-83 junction box
- LMS-SAS5 mounting kit for sensor

6 Functional test

Always check the correct operation of the alarm after the installation and after making the connections. You should also check the operation every time the separator is emptied or at least once every six months.

6.1 idOil-LIQ sensor functional test with idOil control unit

Functional test:

1. The sensor is in the air. The control unit should be in normal mode; indicator lights are off (idOil-20) and there are no alarm notifications on the screen (idOil-30 and idOil-D30), the relays are energised and the buzzer is silent.
2. Lower the sensing element of the sensor into the water or the oil. The control unit's Tank full indicator light should light up or an alarm notification should appear on the screen within 10 seconds, after which the relay(s) should be de-energised, the buzzer should let out an alarm sound and the local screen's backlight should start blinking after the set delay.
3. Lift the sensor in the air. The indicator light should turn off or the alarm notification should disappear within 10 seconds and the relay(s) and the buzzer should revert to their normal state after the set delay.

Clean the sensor of any contaminants that it might have accumulated during the functional test before placing it back in the separator.

If the sensor does not function as described, check the device settings from the control unit's installation and operating instructions or contact the representative of the manufacturer.

6.2 idOil-LIQ sensor functional test with SET control unit

Functional test:

1. The sensor is in the air. The control unit should be in normal mode; indicator lights are off, the relays are energised and the buzzer is silent.
2. Lower the sensing element of the sensor into the water or the oil. The control unit's Hi level alarm indicator light should light up, after which the relay(s) should be de-energised and the buzzer should let out an alarm sound after the set delay (5 seconds or 30 seconds).
3. Lift the sensor in the air. The indicator light should turn off and the relay(s) and the buzzer should revert to their normal state after a delay (5 seconds or 30 seconds).

Clean the sensor of any contaminants that it might have accumulated during the functional test before placing it back in the separator.

If the sensor does not function as described, check the device settings from the control unit's installation and operating instructions or contact the representative of the manufacturer.

7 Maintenance

The sensor should be cleaned every time the separator is emptied and at least once every six months during maintenance inspection. For cleaning the sensor you can use e.g. dishwashing detergent and brush.



Do not use corrosive substances to clean the sensors.



The idOil sensors do not have wearing or replaceable parts.

8 Troubleshooting

8.1 idOil sensor troubleshooting with idOil control unit



EXPLOSION HAZARD!

Observe the installation and maintenance instructions for explosive atmospheres! The measuring device must be Exi classified if the sensor is in an explosive area.



idOil-30, idOil-D30: Remember to set the device in maintenance mode so that the alarms during the maintenance measures are recorded in the inspection log instead of the alarm log. For detailed instructions on how to set the device in maintenance mode, please refer to the control unit's operation and installation manual.



The sensor cable wires are not numbered because the voltage polarity (+ or -) makes no difference.

PROBLEM:

Fault alarm is on:

idOil-20: The sensor alarm indicator light is flashing red and the fault indicator light is red (cable cut or loose) or the alarm indicator lights of all sensors and the fault indicator light are red (short circuit).

idOil-30, idOil-D30: Fault alarm on (the backlight of the display is flashing).

Explanation:

The sensor cable is short-circuited, cut or disconnected from the connector. The sensor could also be damaged.

Action:

1. Measure voltage separately from that sensor's sensor connectors. The voltage should be 9.0–11.5 V.
2. If the voltage is correct, measure the current drawn by the sensor as follows:
 - 2.1 Disconnect the sensor wire from the control unit's left-hand side sensor connector.
 - 2.2 Connect an mA meter as shown in the figure below.
 - 2.3 SENSOR connectors can have 1–3 sensors connected to it, with a single sensor drawing 6.0–8.0 mA of current.
 - 2.4 Reconnect the disconnected wire after the measurement.

The measurement can also be carried out on the separator end by opening the cable extension.

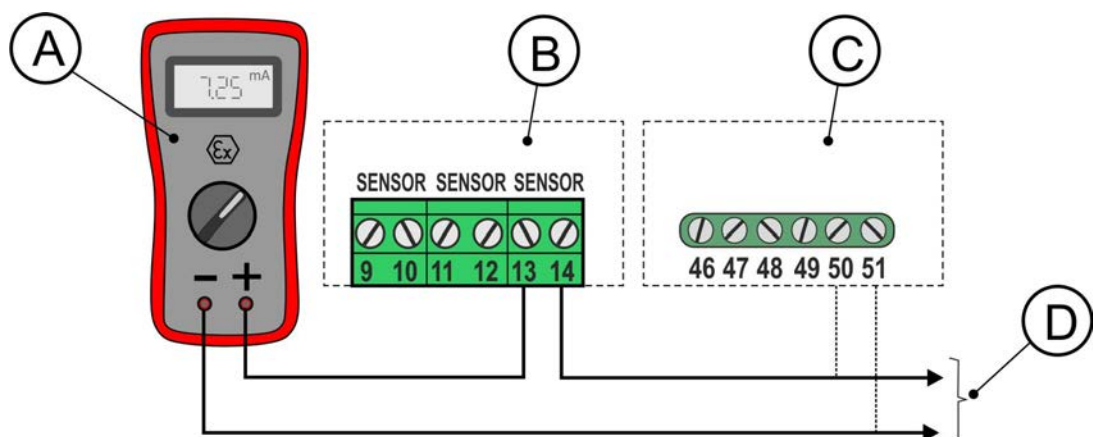

A Ex-classified mA current meter

B idOil-20, idOil-30 control unit's sensor connectors 9–10 or 11–12 or 13–14

C idOil-D30 control unit's sensor connectors 46–47 or 48–49 or 50–51

D idOil sensor(s)

Figure 7 . Measuring sensor current; idOil control unit - idOil sensor(s)

If problems occur, contact Labkotec Oy's service department.

8.2 idOil-LIQ sensor troubleshooting with SET control unit



EXPLOSION HAZARD!

Observe the installation and maintenance instructions for explosive atmospheres!
The measuring device must be Exi classified if the sensor is in an explosive area.



The sensor cable wires are not numbered because the voltage polarity (+ or -) makes no difference.

PROBLEM: Fault alarm is on:
The sensor circuit's Fault indicator light is on and the buzzer is sounding.

Explanation: The sensor cable is short-circuited, cut or disconnected from the connector. The sensor could also be damaged.

Action:

1. Measure voltage separately from that sensor's sensor connectors. The voltage should be 10.0 - 12.0 V.
2. If the voltage is correct, measure the current drawn by the sensor as follows:
 - 2.1 Disconnect the sensor wire from the control unit's + sensor connector.
 - 2.2 Connect an mA meter as shown in the figure below.
 - 2.3 The current value should settle within 10 seconds as follows:
 - sensor in air 5–8 mA
 - sensor in water/oil 10–14 mA
 - 2.4 Reconnect the disconnected wire after the measurement.

The measurement can also be carried out on the separator end by opening the cable extension / junction box.

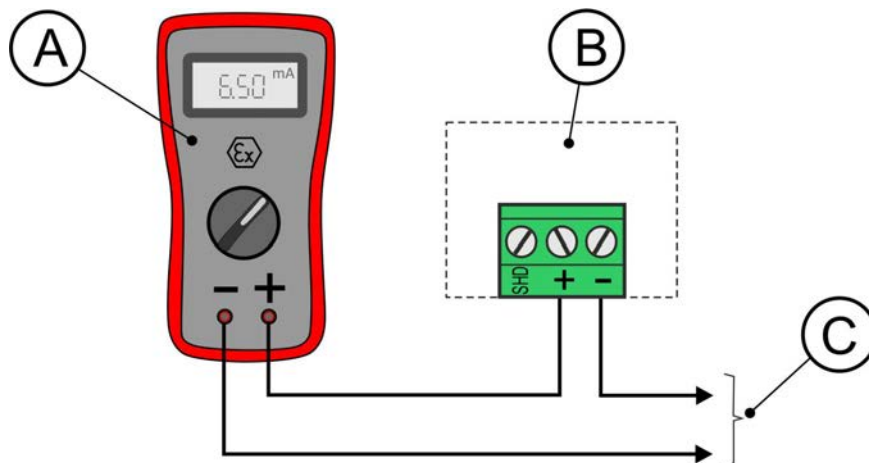

- A Ex-classified mA current meter
- B SET-1000/2000 series control unit's sensor connector
- C idOil-LIQ sensor

Figure 8 . Measuring sensor current; SET-1000/2000 control unit - idOil-LIQ sensor

If problems occur, contact Labkotec Oy's service department.

9 Technical specifications idOil-LIQ high liquid level sensor

TECHNICAL SPECIFICATIONS idOil-LIQ	
Operating principle	Vibration
Enclosure	Enclosure class: IP 68 Materials: PVC, aluminium, PA, CR, Viton
Weight	240 g (incl. 5 m cable)
Temperature	Operation: 0 °C...+60 °C Environment: -30 °C...+60 °C
Supply voltage	7,5...16 V DC
Cable	2 x 0.75 mm ² PUR, Ø5 mm
EMC	EN IEC 61000-6-2 EN IEC 61000-6-3
ATEX and IECEx	EESF 19 ATEX 002X IECEx EESF 19.0002X
Ex classification Special terms (X)	⊕ II 1 G Ex ia IIB T5 Ga Ta = -30 °C...+60 °C
Exi connection values	Ui = 16 V, li = 80 mA, Pi = 400 mW Ci ≤ 5.2 nF, Li ≤ 1.6 mH
Manufacturing year: Please see the serial number on the type plate.	xxxxxxx x xxx xx YY x where YY = manufacturing year (e.g. 18 = 2018)

10 Appendix EU Declaration of Conformity



EU DECLARATION OF CONFORMITY

We hereby declare that the product named below has been designed to comply with the relevant requirements of the referenced directives and standards.

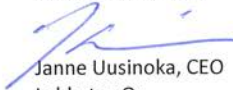
Product	Level sensor idOil-LIQ
Manufacturer	Labkotec Oy Myllyhaantie 6 FI-33960 Pirkkala Finland
Directives	The product is in accordance with the following EU Directives: 2014/30/EU Electromagnetic Compatibility Directive (EMC) 2014/34/EU Equipment for Potentially Explosive Atmospheres Directive (ATEX) 2011/65/EU Restriction of Hazardous Substances Directive (RoHS)
Standards	The following standards were applied: EMC: EN IEC 61000-6-2:2019 EN IEC 61000-6-3:2021 ATEX: EN IEC 60079-0:2018 EN 60079-11:2012 EU-type examination certificate: EESF 19 ATEX 002X. Notified Body: Eurofins Expert Services Oy, Notified Body number 0537. RoHS: EN IEC 63000:2018 The product is CE-marked since 2017.
Signature	This declaration of conformity is issued under the sole responsibility of the manufacturer. Signed for and on behalf of Labkotec Oy. Pirkkala 16.6.2021  Janne Uusinoka, CEO Labkotec Oy



EU DECLARATION OF CONFORMITY

We hereby declare that the product named below has been designed to comply with the relevant requirements of the referenced directives and standards.

Product(s)	LCJ1-1 cable connector for one sensor LCJ1-2 cable connector for two sensors LCJ1-3 cable connector for three sensors
Manufacturer	Labkotec Oy Myllyhaantie 6 FI-33960 Pirkkala Finland
Directives	The product is in accordance with the following EU Directives: 2014/34/EU Equipment for Potentially Explosive Atmospheres Directive (ATEX) 2011/65/EU Restriction of Hazardous Substances Directive (RoHS)
Standards	The following standards were applied: ATEX: EN IEC 60079-0:2018 EN 60079-11:2012 The product is a simple apparatus according to EN 60079-11:2012 (Intrinsic Safety i). RoHS: EN IEC 63000:2018 The product is CE-marked since 2018.
Signature	This declaration of conformity is issued under the sole responsibility of the manufacturer. Signed for and on behalf of Labkotec Oy.

Pirkkala 16.6.2021

Janne Uusinoka, CEO
Labkotec Oy